

# VIBRATION METER

840063

Instruction Manual

SPER  
SCIENTIFIC

*Environmental Measurement Instruments*

## CONTENTS

|      | Title                                       | Page |
|------|---|------|
| I.   | Introduction.....                           | 2    |
| II.  | Panel Description .....                     | 3    |
| III. | Operating Instructions                      |      |
|      | A. General Measurement Procedures .....     | 3~4  |
|      | B. Peak.....                                | 5    |
|      | C. Data Hold.....                           | 5    |
|      | D. Data Record .....                        | 5    |
|      | E. Automatic Shut Off.....                  | 5    |
|      | F. RS232 PC Serial Interface.....           | 5~6  |
|      | G. Battery Replacement.....                 | 6    |
|      | H. Optional Accessories .....               | 6    |
|      | I. Classification Ranges.....               | 6~7  |
|      | J. ISO 2954 Sensitivity Relative Table..... | 7    |
| IV.  | Specifications .....                        | 7~8  |
| V.   | Warranty.....                               | 8    |

---

### I. INTRODUCTION

The level of vibration is a useful guide to the balance, alignment and general condition of pumps, motors, and other machinery. Poor balance, misalignment and looseness results in higher levels of vibration and indicates maintenance is required for operational as well as safety reasons. Measures velocity and acceleration. The large display indicates RMS, Peak, min-max, hold, and low battery. Features auto power off and an RS232 computer interface. Comes ready to use in a foam-lined, hard-shell carrying case, with a detachable strongly magnetic probe, 9V battery and instructions.

## II. PANEL DESCRIPTION (fig. A)

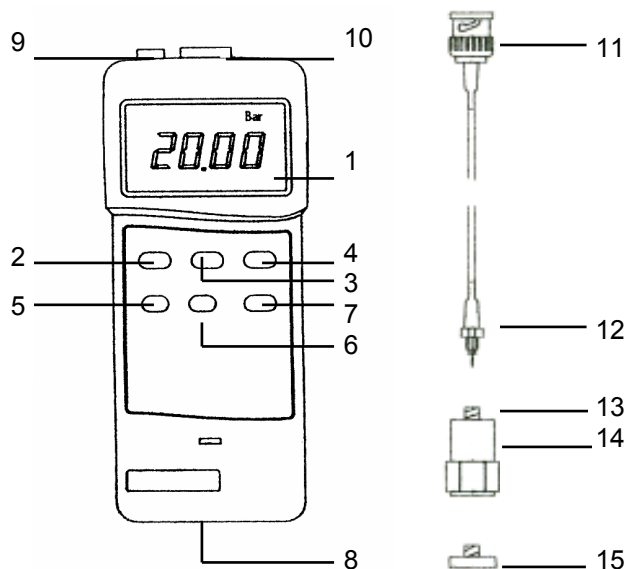

- |                      |                          |
|----------------------|--------------------------|
| 1. DISPLAY           | 9. RS232 OUTPUT TERMINAL |
| 2. POWER BUTTON      | 10. BNC SOCKET           |
| 3. HOLD BUTTON       | 11. BNC PLUG             |
| 4. RMS/PEAK SELECTOR | 12. MINI PLUG            |
| 5. RECORD BUTTON     | 13. INPUT SOCKET         |
| 6. RECALL BUTTON     | 14. VIBRATION SENSOR     |
| 7. ACC/VEL SELECTOR  | 15. MAGNETIC BASE        |
| 8. BATTERY COVER     |                          |

## III. OPERATING INSTRUCTIONS

### A. GENERAL MEASUREMENT PROCEDURES

1. Attached the **BNC PLUG** (A11) to the **BNC SOCKET** (A10).
2. Attached the **MINI PLUG** (A12) to the **INPUT SOCKET** (A13).
3. a. Acceleration (ACC) Measurement:  
Switch the **ACC/VEL SELECTOR** (A7) to the "ACC" position.
- b. Velocity (VEL) Measurement:  
Used for general industrial vibration. Switch the **ACC/VEL SELECTOR** (A7) to the "VEL" position.
4. Switch the **RMS/PEAK SELECTOR** (A4) to the "RMS" position.
5. Press the **POWER BUTTON** (A2) once to turn on the meter.

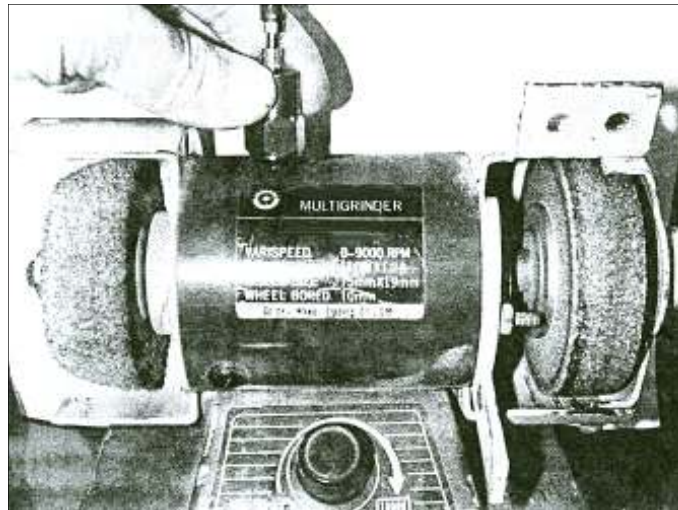

- 6 a. If the surface material of the object you are testing is a non-magnetic material, hold the **VIBRATION SENSOR** and touch the tip to the object (above).
- b. If the surface material is magnetic, connect the **VIBRATION SENSOR** to the **MAGNETIC BASE** (left) and touch it to the object's surface (below).

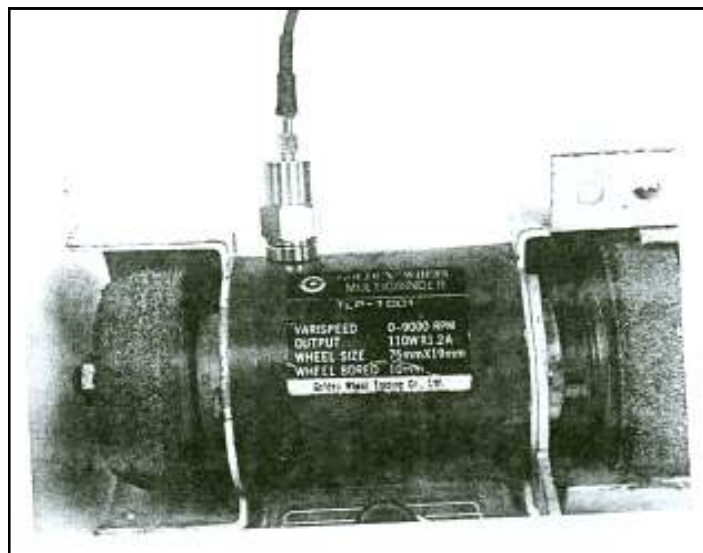

**B. PEAK VALUE**

Switch the **RMS/PEAK SELECTOR** (A4) to the "PEAK" position.  
Peak value = 1.414 RMS value.

**C. DATA HOLD**

1. Press the **HOLD BUTTON** (A3) during measurement to freeze the displayed value. "D.H" is shown on the LCD.
2. Press the **HOLD BUTTON** (A3) a second time to resume measurement.

**D. DATA RECORD (Displays the Maximum and Minimum readings.)**

1. To start the Data Record function, press the **RECORD BUTTON** (A5) once. The LCD display will indicate "REC."
2. Press the **RECALL BUTTON** (A6) and the "Max" symbol (along with the maximum value) will appear on the LCD display.
3. Press the **RECALL BUTTON** (A6) again and the "Min" symbol (along with the minimum value) will appear on the display.
4. To exit the memory record function, press and hold the **RECORD BUTTON** (A5) for approximately 2 seconds. The display will revert back to the current reading.

**E. AUTOMATIC SHUT OFF**

This unit has a built-in automatic shut off function to prolong battery life. The meter will shut off automatically if no buttons are pressed within 10 minutes. To deactivate this feature, select the memory record function during measurement, by pressing the **RECORD BUTTON** (A5).

**F. RS232 PC SERIAL INTERFACE**

The unit features an RS232 output via 3.5 mm Terminal. The connector output is a 16 digit data stream which can be utilized by user's specific application. An RS232 lead with the following connection will be required to link the instrument with the PC serial input.

| Meter (3.5 mm jack plug) | PC (9W "D" Connector) |
|--------------------------|-----------------------|
| Center Pin               | Pin 2                 |
| Ground/Shield            | Pin 5                 |

The 16 digit data stream will be displayed as follows:

D15D14D13D12D11D10D9D8D7D6D5D4D3D2D1D0

Each digit indicates the following status:

|                             |   |
|-----------------------------|---|
| DO                          | End Word  |
| D1 to D4                    | Upper Display reading, D1=LSD, D4=MSD   |
| D5 to D8                    | All "?" (? , ? , ? , ?)   |
| D9                          | Decimal Point(DP), position from right to the left ;0 = No DP, 1 = 1 DP, 2 = 2 DP, 3 = 3 DP |
| D10 to D14                  | All Zeros (0, 0, 0, 0, 0)   |
| D15                         | Start Word  |
| RS232 FORMAT: 9600, N, 8, 1 |   |

#### G. BATTERY REPLACEMENT

When the top left corner of LCD display indicates "LBT," it is time to replace the battery. Accurate readings may be taken for several hours after the low battery indicator appears. Open the battery cover, install a fresh 9V battery and replace the cover.

#### H. OPTIONAL ACCESSORIES

- 850080 Software
- 840094 RS232 to USB Adaptor Cable
- 840055 RS232 cable 48" required for use w/software
- 840090 Water Resistant Instrument Pouch

#### I. CLASSIFICATION RANGES

There are 4 different machine groups with 4 classification ranges and

| <b>GROUP K: Small machines, especially production electrical motors of up to 15 KW.</b>                                   |                  |
|---|------------------|
| Good  | 0 ~ 0.71 mm/s    |
| Acceptable  | 0.72 ~ 1.80 mm/s |
| Still permissible   | 1.81 ~ 4.5 mm/s  |
| Dangerous   | > 4.5 mm/s       |
| <b>GROUP M: Medium sized machines, especially electrical motors with 15 to 75 KW output, without special foundations.</b> |                  |
| Good  | 0 ~ 1.12 mm/s    |
| Acceptable  | 1.13 ~ 2.80 mm/s |
| Still permissible   | 2.81 ~ 7.1 mm/s  |
| Dangerous   | > 7.1 mm/s       |

| <b>GROUP G: Large machines on heavy foundations.</b>                          |                  |
|---|------------------|
| Good  | 0 ~ 1.80 mm/s    |
| Acceptable  | 1.81 ~ 4.50 mm/s |
| Still permissible   | 4.51 ~ 11.2 mm/s |
| Dangerous   | > 11.2 mm/s      |
| <b>GROUP T: Largest machines and turbo machines with special foundations.</b> |                  |
| Good  | 0 ~ 2.80 mm/s    |
| Acceptable  | 2.81 ~ 7.10 mm/s |
| Still permissible   | 7.11 ~ 18.0 mm/s |
| Dangerous   | > 18 mm/s        |

**J. ISO 2954 Sensitivity Relative Table**

| Frequency Hz | Relative sensitivity |               |               |
|--------------|----------------------|---------------|---------------|
|              | Normal Value         | Minimum Value | Maximum Value |
| 10           | 1.0                  | 0.8           | 1.1           |
| 20           | 1.0                  | 0.9           | 1.1           |
| 40           | 1.0                  | 0.9           | 1.1           |
| 80           | 1.0                  | 1.0           | 1.0           |
| 160          | 1.0                  | 0.9           | 1.1           |
| 500          | 1.0                  | 0.9           | 1.1           |
| 1000         | 1.0                  | 0.8           | 1.1           |

**IV. SPECIFICATIONS**

|              | Range                        | Resolution           | Accuracy  |
|--------------|------------------------------|----------------------|---|
| Acceleration | 0.5 ~ 199.9 m/s <sup>2</sup> | 0.1 m/s <sup>2</sup> | +/- (5% +2d) rdg,<br>160 Hz, 80 Hz.<br>@ 23 +/- 5°C |
| Velocity     | 0.5 ~ 199.9 mm/s             | 0.1 mm/s             |   |

### SPECIFICATIONS (continued)

|                      |   |
|----------------------|---|
| Frequency            | 10 Hz~ 1 KHz, sensitivity relative during the frequency range meets ISO 2954 (see pg 6).      |
| Weight               | Meter with battery: 10 oz (230 g).<br>Probe with magnetic base: 2 oz (50 g).                  |
| Dimension            | Meter: 17" x 3" x 1 ½" (80 x 75 x 35 mm)<br>Probe cord: 49" (125 cm), probe diameter: (19 mm) |
| Display              | 61 mm x 34 mm super large LCD display.<br>15 mm (0.6") digit size.                            |
| Calibration Point    | Velocity: 50 mm/s (160 Hz)<br>Acceleration: 50 m/s <sup>2</sup> (160 Hz)                      |
| Sampling time        | Approx. 1 second.   |
| Operating conditions | Temperature: 0 ~ 50°C (32 ~ 122°F)<br>Humidity: Less than 80% R.H.                            |
| Power supply         | Alkaline or heavy duty type DC 9V battery.  |
| Power consumption    | Approx. DC 6 mA.  |
| Circuit              | Exclusive microcomputer circuit.  |

### V. WARRANTY

Sper Scientific warrants this product against defects in materials and workmanship for a period of one (1) year from the date of purchase, and agrees to repair or replace any defective unit without charge. If your model has since been discontinued, an equivalent Sper Scientific product will be substituted if available. This warranty does not cover probes, batteries, or damage resulting from accident, misuse, or abuse of the product. In order to obtain warranty service, simply ship the unit postage pre-paid to:

SPER SCIENTIFIC, 7720 East Redfield, Suite 7 Scottsdale, AZ 85260  
(480) 948-4448, info@sperscientific.com, www.sperscientific.com.

The defective unit must be accompanied by a description of the problem and your return address. Register your product online or return your warranty card within 10 days of purchase.